

Elmes STM-2K controller is designed for remote control of two devices powered by 230VAC such as lamps, motors, etc. Miniature size of the controller allows its installation in electric installation boxes (wall plaster type – 60mm deep). Wall switch, if used for wired control, may be single (if only one channel will be used) or double (for two outputs to be used) button. The wall switch should be a monostable type (automatic off). The receiver includes the *KEELOQ®* code-hopping system of Microchip Technology Inc., USA for highest level of security.

STM-2K receiver is compatible with all Elmes hand transmitters operating at 433,92 MHz. Dedicated two channel transmitters DWB100HT, DW200HT control both channels of the receiver. Elmes 4 or 8 channel transmitters may control two or more receivers in the following way: transmitter channels work in pairs: channel 1 and 2 control one receiver, transmitter's channels 3 and 4, 5 and 6, 7 and 8 may control another receivers.

STM-2K may be wired operated by two single monostable wall switches or one double. Wired switches control the unit the same way as the hand transmitters.

Each output of the receiver is independent and may be programmed to operate in one of the following modes:

Mode 1: (default) The receiver's output is switched ON or OFF each time the hand transmitter's button is pressed (programming procedures point 2)

Mode 2: As above, but if the output has been left in the ON position, it will switch OFF automatically after pre-programmed time (programming procedure point 3)

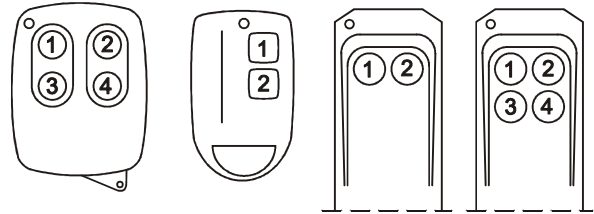
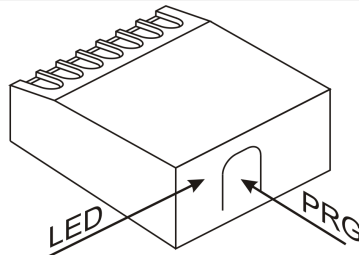

Fig.1. Layout of buttons in Elmes hand held transmitters

PROGRAMMING PROCEDURES

The STM-2K controller programming is made using PRG button with LED status indication, as shown on the side figure. LED slow flashing speed (one per second) indicates correctly performed procedure. Fast flashing (four per second) indicates procedures made incorrectly or procedure error. Programming procedures, except for procedure point 2b and 3c,d, are allowed 16 seconds to be completed. After that time the controller automatically exits programming mode and indicates programming error.



1. LEARNING TRANSMITTER/S to controller's memory (up to 112 maximum):

- press control unit PRG switch for less than 2 seconds (LED lights on). Releasing the switch LED continues to light indicating entering programming mode,
- press appropriate transmitter's button once (button number 1 or 2 for control pair 1-2, button number 3 or 4 for control pair 3-4) - LED switches off.
- press the same transmitter's button second time - end of procedure

2. MODE 1 PROGRAMMING PROCEDURE (see above):

- press **and hold** PRG switch for longer than 2 and shorter than 8 seconds. Releasing the switch sets the LED off,
- press shortly three times (3) programmed transmitter button or wall switch.

3. MODE 2 PROGRAMMING PROCEDURE (see above):

- press **and hold** PRG switch for longer than 2 and shorter than 8 seconds. Releasing the switch sets the LED off
- press hand transmitter button or wall switch once – the LED lights ON and the output sets ON,

- when the desired time has elapsed (from 0,5 second up to 4,5 hours) press the transmitter button or wall switch again
- after 2 seconds the LED starts blinking slowly confirming end of procedure

4. DELETING ALL TRANSMITTERS in controller's memory. Procedure suitable in case one of transmitters is stolen or lost: Press **and hold** PRG switch (LED lights) in controller until LED starts flashing (over 8 seconds) and then release it. The controller's memory is now cleared of all transmitters, however programmed modes and timing remain unchanged. To operate the controller by hand transmitter/s perform point 1.

5. DELETING ONE TRANSMITTER in controller's memory. This operation is possible under condition that the transmitter to be deleted is in our possession. Start the procedure as in point 1a) and follow steps by pressing **two different buttons** of the transmitter. LED indicating error in this case means the transmitter is now deleted and will no longer operate the controller. Status of all other transmitters learned to the controller remains unchanged.

NOTE: procedure point 2 and 3 is possible with the wall switch or programmed hand transmitter.

INSTALLATION (see connection schematic diagram below):

WARNING! Control unit and electric connection to 230VAC mains voltage require personal safety procedures to be taken and mains voltage line be in OFF state at installation.

The controller is not water sealed and should be installed in dry place. Antenna wire should be let loose downwards (not glued or fitted to ground), if possible. Care should be taken not to expose the control unit to harsh environmental conditions such as very low/high temperatures or high humidity. The unit includes radio receiver thus any metal screening or interference with other electric/radio equipment operating in close distance should be avoided as may seriously shorten practical operating range in wireless operating mode. When installing the controller in electric junction box (in wall) care should be taken to properly lay connecting wires avoiding crossing with antenna wire. The antenna wire should be laid in circular way and tested for obtaining maximum operating range with the use of hand transmitter/s.

Description of STM connection terminals:

- 1 – 230VAC mains **LIVE** output for channel number 1,
- 2 – common **NEUTRAL** output for channels 1 and 2,
- 3 – 230VAC mains **LIVE** output for channel number 2,
- 4 - **230VAC mains LIVE supply input (!)**,
- 5 - **230VAC mains NEUTRAL supply input (!)**,
- 6 – wired wall switch input for channel 1 (**LIVE!**),
- 7 – wired wall switch input for channel 2 (**LIVE!**),

(!!!) WARNING: It is important to connect mains supply LIVE wire to terminal 4 and NEUTRAL wire to terminal 5 of the controller.

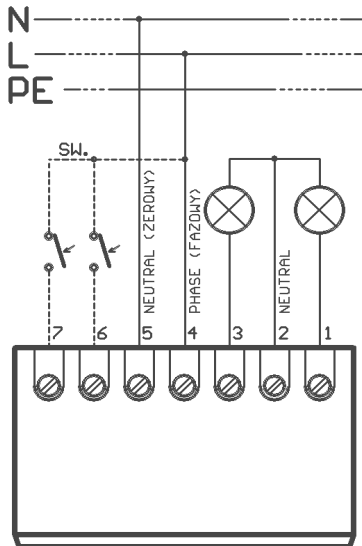

SPECIFICATION

- power supply 230VAC (0,3VA standby, 0,5VA on any relay set on),
- output relays rating: 250VAC~ 5A max.,
- superheterodyne receiver to 433,92MHz band,
- controller's memory for up to 112 transmitters,
- control voltage at inputs no 6 and 7: 250VAC~ max.,
- programmed timing: 0,5s up to 4h,
- operating temperature range -20 up to +55°C,

- external dimensions (l/w/h) 42/35/21mm.

Manufacturer

ELMES ELECTRONIC, 54-611 Wroclaw-PL, Avicenny Str.2, tel. (+4871) 784-59-61, fax 784-59-63

Manufacturer's Limited Warranty:

Elmes Electronic products carry two year manufacturer's warranty as from date of purchase. The warranty is limited to the replacement of faulty original parts or repair defects of improper manufacture. Damage, faulty use or improper handling by the user or installer as well as any changes in product's hardware or software caused by the user violets the warranty and all due repair costs will be charged. Elmes Electronic shall not be responsible for any damage human or material caused by its products failure to operate correctly.

Elmes Electronic reserves the right to change product specification without prior notice.

KEELOQ® is a registered trademark of Microchip Technology Inc.

WARNING! Do not open the product, warranty void if seal is broken.

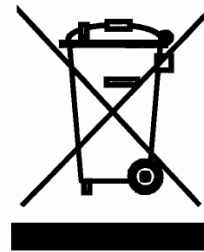

The use of WEEE symbol indicates that this product cannot be treated as house hold waste. By ensuring this product is disposed of correctly you will protect the environment. For more detailed information about the recycling of this product, please contact your local authority, your household waste disposal service provider or the shop where you purchased the product.



DECLARATION OF CONFORMITY

Product: Miniature Wireless Roller Controller Elmes STM
Manufacturer: Elmes Electronic, Avicenny 2, Wroclaw-PL

We, the manufacturer, declare that the product is designed and manufactured in compliance with European Union R&TTE 1999/5/EC and 73/23/EEC Directives, in particular in accordance with following harmonized standards:

- concerning electrical equipment:
EN 50371:2002, EN 60730-1:2000,
- concerning radio requirements:
EN 300 220-3 V1.1.1:2000
- concerning electromagnetic compatibility:
EN 301 489-1:2004, EN 301 489-3:2002

Wroclaw, 16.02.2009

Director – Miroslaw Binkowski

